

**Model 4150  
Infrared Spot Heater  
Instruction Manual**

Publication No. 098217-001 Rev. B



September 1998



Research Inc. 7128 Shady Oak Road, Eden Prairie, MN 55344 (952) 941-3300 Fax (952) 941-3628 [www.researchinc.com](http://www.researchinc.com)

[www.researchinc.com](http://www.researchinc.com)

## Section 1 INTRODUCTION

## Section 2 SAFETY

General . . . . .	2-1
Infrared Radiation . . . . .	2-1
High Temperatures . . . . .	2-1
Electrical Safety . . . . .	2-1
Fire Safety . . . . .	2-2
Maintaining Proper Air Flow for Heater Cooling . . . . .	2-2

## Section 3 INSTALLATION

Unpack and Check for Damage . . . . .	3-1
Install Cooling Air Tubing . . . . .	3-1
Install the Power Cord . . . . .	3-1
Mounting the Heater . . . . .	3-2
Installation to Model 5620 SCR Power Controller (Optional) . . . . .	3-3
Install Focusing Cone (Optional) . . . . .	3-3
Install Ruby Red Glare Reduction Shield (Optional) . . . . .	3-4

## Section 4 OPERATING INSTRUCTIONS

## Section 5 MAINTENANCE

Model 4150 Emitter Replacement . . . . .	5-1
------------------------------------------	-----

## Section 6 SPECIFICATIONS

## Section 7 PC OPTION – MODEL 4150 HEATER WITH MODEL 5620 SCR POWER CONTROLLER

Introduction . . . . .	7-1
'PC' Option . . . . .	7-2
Safety . . . . .	7-2
General . . . . .	7-2
Electrical Safety . . . . .	7-2
Installation . . . . .	7-3
Installing the Model 5620 . . . . .	7-3
Connecting the LOAD and LINE Wires . . . . .	7-4

---

Output Conditioning Selection .....	7-4
Installing an Optional Remote Timer-Start Switch .....	7-5
Operation .....	7-7
How to Use the Standby-Operate Switch .....	7-7
Operating the RUN/IDLE/TIMER Features .....	7-7

# Introduction

The Model 4150 electric infrared heater (Fig. 1-1) is designed for use in any application that requires clean, non-contact heat on a small target or object. Typical applications for this heater includes:

- Metal annealing
- Soldering and desoldering electronic components
- Heating thermoplastic composites
- Localized weld stress relief
- Brazing

The Model 4150 uses a high intensity, short wave infrared emitter rated for 120 volt, 60 Hz operation. The Model 4150 emitter generates 250 watts at full (rated) power. The emitter reaches 90% output within 3 seconds of applied power and can heat specific targets up to 2000°F (1093°C). The highest energy is concentrated within a 0.25 inch (6.3 mm) 'spot' approximately 1.0 inch (25 mm) from the end of the heater collar or at the end of the optional focusing cone (Fig. 1-2). Mounting the Model 4150 is accomplished using the 1/4 - 20 NPT threaded hole located on the back of the heater.

Due to the high heat output from the Model 4150, it is necessary to supply cooling air at 100 CFH to maintain proper operating conditions and prolong heater life. An air hose fitting is supplied with the heater and accepts 0.25-inch (6.3-mm) outer diameter flexible tubing. An internal thermostat automatically removes power to the emitter in the event the heater temperature rises above 280°F (137°C). A clear quartz window protects the emitter from contamination and other harmful elements that may reduce its life. A 6-ft. (1.83 m) "quick disconnect" electrical cord with a male, 1/4 turn electrical safety plug is also supplied with the heater.

Available options for the Model 4150 include an energy focusing cone, a 'ruby red' quartz glare reduction shield, and the ability to order to Research, Inc. Model 5620 SCR Power Controller along with the heater.

Figure 1-1 4150 Spot Heater

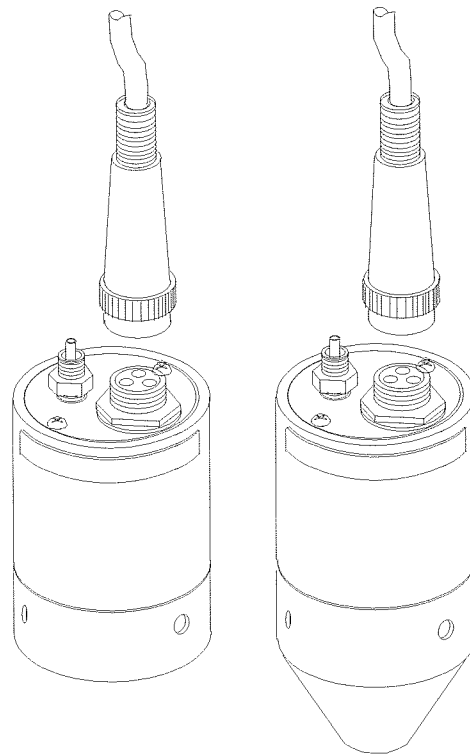

00068

Figure 1-2 Focal point of 4150 spot heater

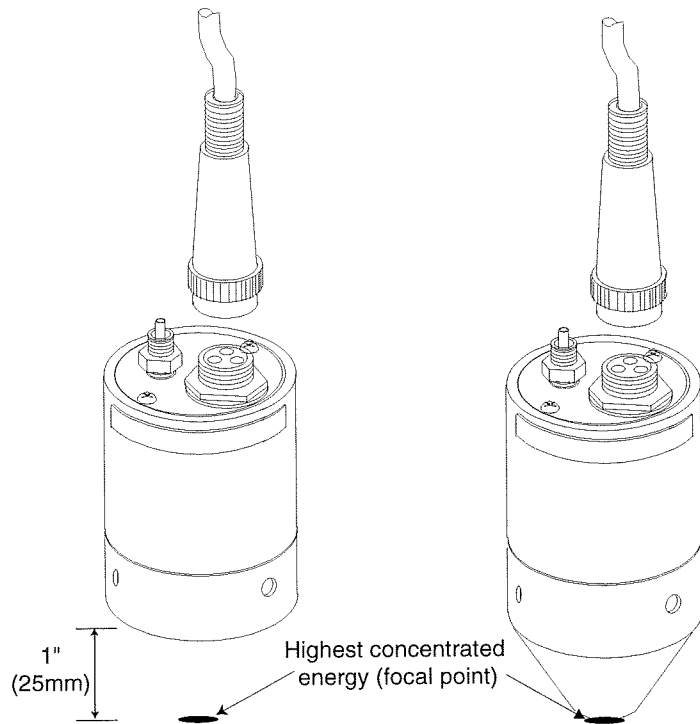

00069

# Safety

## GENERAL

The Model 4150 Spot Heater is designed for safe operation. Nevertheless, installation, maintenance and operation of the heater can be dangerous for a careless operator or maintenance person. For your safety and the safety of others, please read the instructions in this INSTRUCTION MANUAL and follow these safety practices which will help to prevent accident or injury.

## INFRARED RADIATION

---

**CAUTION!**

Continuous exposure to high intensity infrared radiation at close proximity could be harmful to eyes or skin. Although ultra violet electromagnetic radiation is not being emitted by infrared lamps, harmful burns could still result if an operator is in close contact with lamps being operated at high intensity.

Because of the brilliant light emitted by infrared lamps at full intensity, it is recommended that the eyes be shielded from the glare if observing the lamps or radiant heat chamber for an extended period of time. Use suitable shaded lenses or dark glasses.

---

## HIGH TEMPERATURES

Parts of the heater may exceed 500°F (260°C). Contact with the lamps, reflectors, or metal parts near the lamps may cause severe BURNS.

---

**⚠ WARNING**

NEVER place hands under the heating elements.

ALWAYS allow heating element to cool at least 5 minutes before touching the lamps or adjacent parts.

---

## ELECTRICAL SAFETY

There is danger of electrical shock when servicing the heater.

---

**CAUTION!**

Observe that all applicable local and national electrical codes are met and a safe electrical ground system is installed before attempting to operate the heater. Refer to the Section 3 for proper installation procedures.

---

---

**⚠ WARNING!**  
ALWAYS disconnect the external power lines prior to servicing the heater.

ALWAYS disconnect the power lines AND any optional interlock circuits before installing or changing lamps.

NEVER operate the heater with the heater end covers removed.

---

## FIRE SAFETY

1. Obey the same fire-safety rules you observe when you work with hot plates, high intensity infrared heaters, propane or acetylene torches, soldering irons, and other equipment that gets very hot.
2. Remove all solids, liquids, and gases that burn easily from the area around the heater.
3. Know where the nearest fire extinguisher is located and how to use it.
4. Know how to put out fires from all the types of material near the Model 4150 Heater.

## MAINTAINING PROPER AIR FLOW FOR HEATER COOLING

The Model 4150 heater requires air flow of 100 CFM to operate properly and prolong its life. An air hose fitting is supplied with the heater and accepts 0.25-inch (6.3-mm) outer diameter tubing. Flexible tubing such as polypropylene or high temperature rubber is recommended for use with the Model 4150.

Failure to supply sufficient cooling to the Model 4150 will cause it to overheat and invoke the thermostat to cease power to the emitter. The thermostat will reset after it falls sufficiently below its set point of 280°F (137°C).

# Installation

## UNPACK AND CHECK FOR DAMAGE

Remove the Model 4150 heater from its shipping container and associated packaging. Check the entire unit for any potential damage due to shipping. In the unlikely event damage has occurred, keep all shipping containers and materials and file a damage claim with the shipping company that delivered the heater.

## INSTALL COOLING AIR TUBING

Cooling air at 100 CFH must be supplied to the Model 4150 in order for the heater to operate properly. A brass fitting is located on the back of the heater which accepts 1/4 inch (6.3 mm) outer diameter tubing (Fig. 3-1). It is recommended that flexible tubing be used to simplify mounting of the heater.

Figure 3-1 Installing cooling air tubing

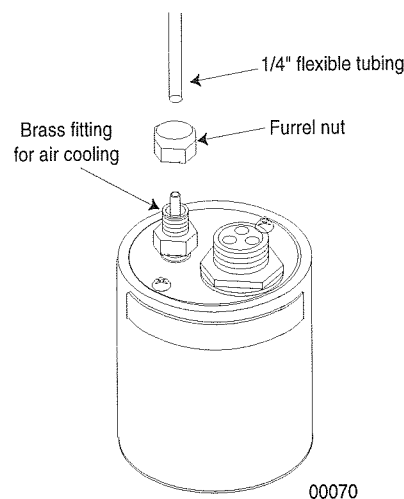

## INSTALL THE POWER CORD

The Model 4150 power cord is 6 feet long (1.83 m) and has a “quick disconnect” style plug which allows for easy installation and removal from the heater. Located at the opposite end of the cord is the 1/4-turn male, electrical safety plug. This connector requires a matching female electrical safety receptacle for proper installation. (This type of receptacle is found on the Research Inc. Model 5620 SCR Power Controller).

The Model 4150 power receptacle is located on the back of the heater (Fig. 3-2). The “quick disconnect” plug is round with one flat side and has three pins that are inserted into the receptacle. The flat of both the receptacle and plug should be aligned before tightening one into the other.

Plug the 1/4-turn male, electrical safety plug into an appropriate female receptacle connected to the power source.

Figure 3-2 Installing the power cord

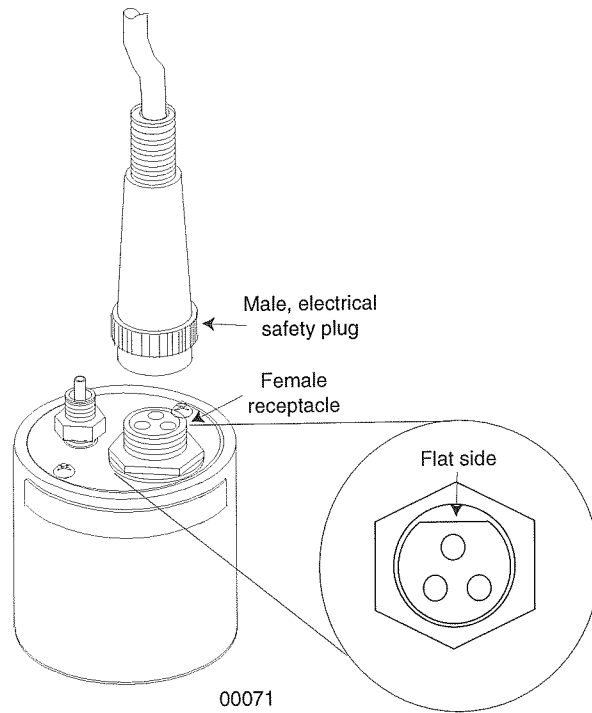

## MOUNTING THE HEATER

The Model 4150 heater can be mounted to any acceptable bracket, fixture, or other machinery that will support the heater's weight. A 1/4-20 NPT tapped hole is located on the back of the heater that will accept a similarly threaded screw (Fig. 3-3).

**NOTE:**

*Maximum extension of the screw into the heater should be no more than 0.375-inch (9.5-mm).*

Figure 3-3 Mounting the heater

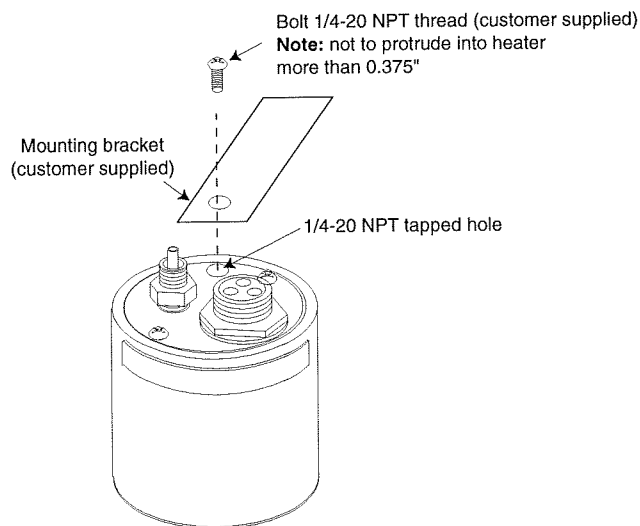

Take special care when mounting the heater so that the power cord and air supply tubing are uninhibited from proper operation.

## INSTALLATION TO MODEL 5620 SCR POWER CONTROLLER (OPTIONAL)

The Model 4150 heater can be ordered with the Model 5620 SCR Power Controller (Option Code 'PC'). When so ordered, the heater, power controller, and all necessary interface wiring to connect both units together are shipped. Both units have 1/4-turn electrical safety plugs and approximately 10 feet (3 m) of cabling to allow sufficient operating space between the heater and power controller.

Plug the male 1/4-turn electrical safety plug on the Model 4150 heater power cord into the female 1/4-turn receptacle attached to the Model 5620 SCR Power Controller. Once connected, turn both (one clockwise and the other counter-clockwise) to secure them together.

Complete the installation of this system by bringing power to the Model 5620 SCR Power Controller. It is strongly recommended that all applicable electrical wiring and safe installation codes and practices should be followed in order for the heating system to operate properly and to eliminate unsafe conditions.

## INSTALL FOCUSING CONE (OPTIONAL)

The standard Model 4150 heater is shipped with a retaining collar and clear quartz window from the factory. An optional focusing cone can be ordered which focuses all the infrared energy from the emitter to a 0.25-inch (6.3 mm) circular spot. The standard clear quartz window is not shipped with the Model 4150 ordered with the focusing cone.

Installation of the focusing cone (ordered as a replacement part) to a standard Model 4150 is easily performed (Fig.3-4). Remove the collar from the heater by grasping the heater in one hand and the collar in the other and turning each approximately 1/8th turn, one clockwise and the other counter-clockwise. Both parts can then be separated from each other.

### **NOTE:**

*The clear quartz window, held in the collar by a retaining ring, is somewhat fragile and will break if not handled with care.*

Figure 3-4 Installing focusing cone

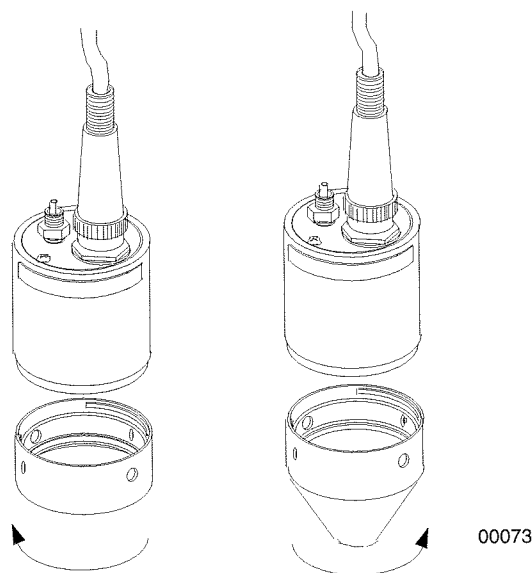

Attach the focusing cone to the Model 4150 by similarly grasping the heater body and focusing cone and turn both together, in opposite directions, until they are snug. Note: the quartz window should not be placed within the focusing cone, doing so will greatly reduce the Model 4150 output.

### INSTALL RUBY RED GLARE REDUCTION SHIELD (OPTIONAL)

The standard Model 4150 heater is shipped with a retaining collar and clear quartz window from the factory. An optional Ruby Red Glare Reduction Shield can be ordered which greatly reduces the amount of glare produced by the heater when power is applied. This glare reduction shield replaces the standard clear quartz window when ordered as an option within the Model 4150 model number (Option Code "RW").

Installation of the Ruby Red Glare Reduction Shield (ordered as a spare or replacement part) within a standard Model 4150 heater is easily performed. Remove the collar from the heater by grasping the heater in one hand and the collar in the other and turning each approximately 1/8th turn, one clockwise and the other counter-clockwise. Both parts can then be separated from each other. Note: both the clear quartz window and the glare reduction shields are somewhat fragile and will break if not handled with care.

Using a fine point, needle-nose pliers or retaining ring pliers, remove the retaining ring from the collar by compressing the ring and lifting it out of the collar (Fig. 3-5). Remove the clear quartz window by gently turning the collar over with one hand and catching the window in the other hand. Set the window in a safe location where it is unlikely to sustain damage.

Figure 3-5 Installing ruby red glare reduction shield

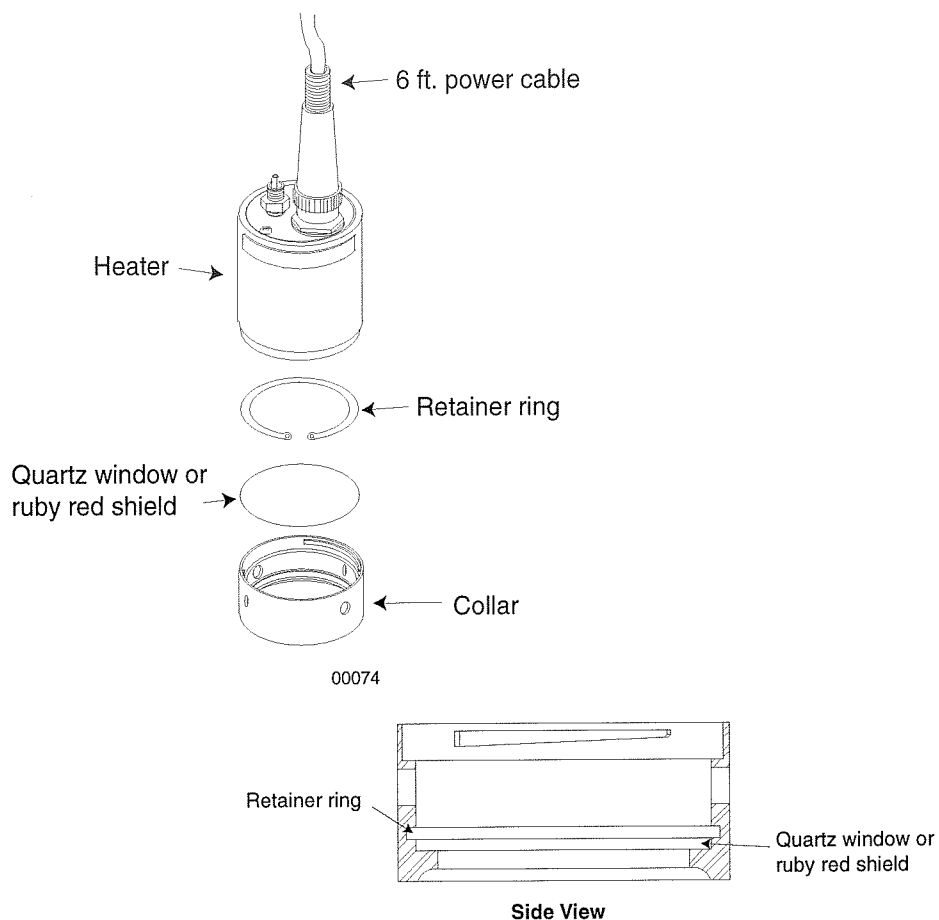

Place the Ruby Red Glare Reduction Shield into the collar in the same location where the clear quartz window resided. Using the pliers, compress the retaining ring and slide the ring into the collar until it rests within the retaining ring groove. Attach the collar to the heater by grasping one in each hand and turn both, in opposite directions, until snug.

# Operating Instructions

Operating the Model 4150 heater is quite simple and straight-forward once properly installed and mounted within a given application. Generally, power to the heater is supplied by a SCR (Silicon Controlled Rectifier) power controller. Typical examples of this type of power controller include the Model 5620 and Model 60906 from Research Inc.

At fully applied power (120 volts) the Model 4150 emitter generates 250 watts of energy. The emitter will generate 90% output within 3 seconds of applied power.

**NOTE:**

*Extreme care should be taken to have the heater pointed away from any object that may burn.*

The maximum infrared energy generated by the Model 4150 will be concentrated at the heater focal point (approximately 1.0 inch (25 mm) from the end of the retaining collar or 0.25 inch (6.3 mm) from the end of the optional focusing cone). A 0.25 inch (6.3 mm) “spot” of energy is visible at the focal point with maximum heating occurring at this distance. Moving the heater closer to or further from the target (relative to the focal point) will decrease the amount of energy impinging on the target resulting in reduced target temperatures.

Due to the wide variety of materials that can be heated with the Model 4150, experimentation with the heater and target material is recommended to determine optimal heater-to-target distance and power requirements.



# Maintenance

The Model 4150 heater requires very little maintenance during its normal lifetime. The life of the heater will be prolonged as long as the proper amount of cooling air (100 CFH) is supplied and the supply voltage to the heater does not exceed specifications.

## MODEL 4150 EMITTER REPLACEMENT

Replacement of the Model 4150 emitter is easily performed and takes very little time. This process is as follows:

**NOTE:**

*Remove all power from the heater BEFORE attempting to replace the Model 4150 emitter.*

1. Holding the heater body in one hand, remove the heater collar or focusing cone (whichever is mounted to the heater) by turning each in opposite directions (ie. one clockwise and the other counter-clockwise).
2. While still firmly holding the heater body, grasp the edge of the emitter and pull it away from the heater body. If damaged or non-functional, discard the used emitter appropriately.
3. Firmly grasp the replacement emitter around its edge, align the two pins protruding from the back of the emitter with the two small holes located in the center of the emitter cavity, and firmly push the emitter into the body cavity [approximately 0.25 inch (6.3 mm)].
4. Replace the heater collar (or focusing ring) in the opposite fashion as was stated in Step 1 above.
5. Reconnect power to the Model 4150 heater.



# Specifications

Figure 6-1 4150 dimensions

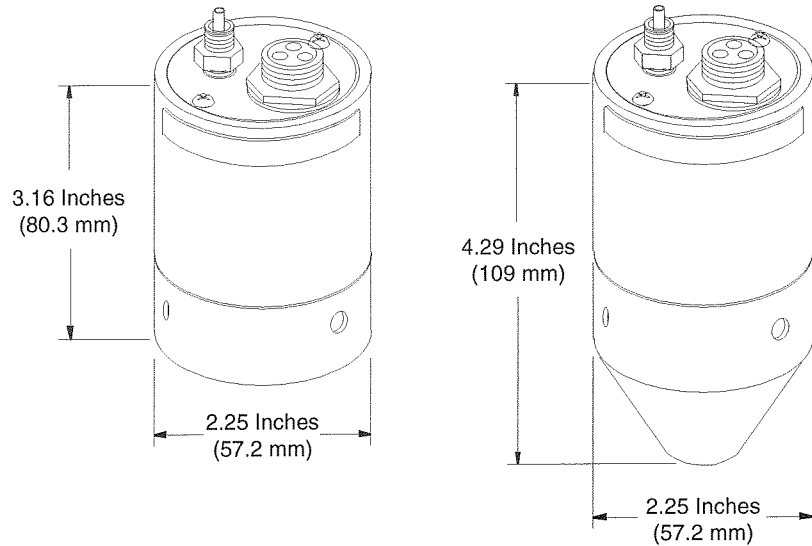
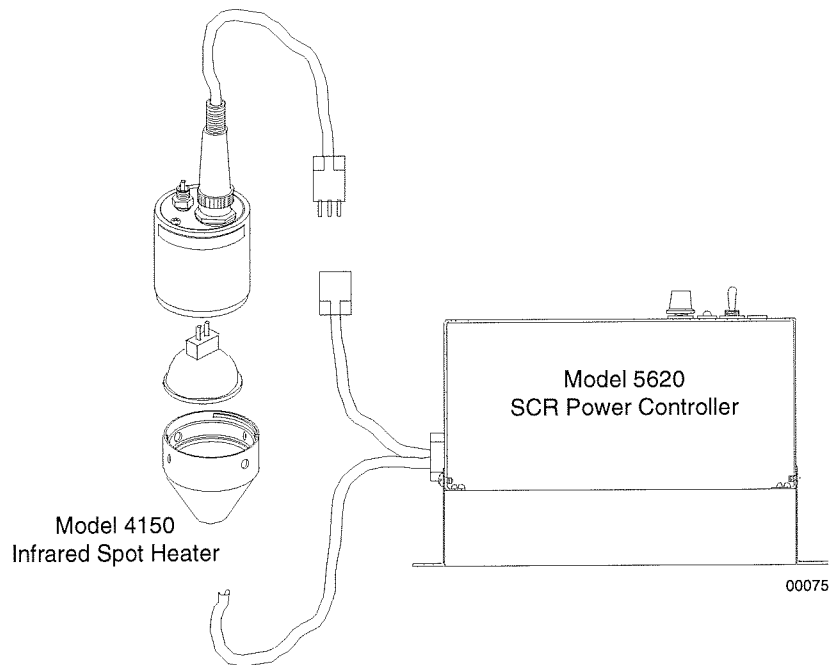

Figure 6-2 Model 4150 Spot Heater with Model 5620 SCR Power Controller



00075

Table 6-1 Ordering Information

Model	Product Description
4150	Infrared Spot Heater with Emitter
Code	Options
RW	Red Quartz Glare Reduction Window
FC	Focus Cone (replaces collar)
PC (1)	Model 4150 Heater supplied with Model 5620 SCR Power Controller and interface wiring
(1) Option PC supplies a Model 4150 SpotIR™ heater with a Model 5620 SCR Power Controller™ and appropriate interface wiring including 1/4-Turn Electrical Safety Plug(s).	

Table 6-2 Ordering Example

	Model	Options		
Typical Model No.	4150	RW	FC	PC

Table 6-3 Accessories, Spare & Replacement Parts

Model	Description
097800-001	Clear Quartz Window
097080-001	Red Quartz Glare Reduction Window
096982-001	Heater Collar
096983-001	Focus Cone
M4150	Additional Operation Manual

Table 6-4 Lamp for Model 4150

Model	Description
096881-001	Replacement Emitter

# PC Option – Model 4150 Heater with Model 5620 SCR Power Controller

## INTRODUCTION

The Model 5620 Power Controller is an economical power controller for manually setting the voltage into resistive loads. It has provision for different idle and run power settings, and a timer to time the application of run power setting. This makes it ideal for laboratory or production applications requiring these capabilities. The 5620 Power Controller is available with current ratings of 20, 35 and 55 amperes for use on 120, 208, 240, 277, 380 and 480 volt power sources.

The phase-angle method of power control is used to provide a smooth application of power to the load from 0 to 100 percent of the line voltage. This makes the Model 5620 Power Controller ideal for tungsten filament lamps and other resistive loads. An output conditioning circuit provides a “slow start” for tungsten filament loads to prevent excessive in-rush current on start-up due to the low resistance of the tungsten when at room temperature.

Line Voltages:	120, 208, 240, 277, 380, 480
Current:	20, 35 and 55 amperes
Line Frequency:	47 to 63 Hertz
Line Regulation:	± 3% RMS load voltage with + 10% to -15% RMS line variations
Internal Feedback:	Average voltage
Idle Adjustment Range:	0% to 30%, minimum
Run Adjustment Range:	0% to 100%
Run Timer Range:	0 to 20 seconds
Output Conditioning:	Fast: 30–60 msec., Ramp: 1 sec., Lamp: 5 sec.
Environmental Limits:	Operating: 32 to 122°F (0 to 50°C) up to 90% relative humidity (non-condensing) Storage: -40 to 158°F (-40 to 70°C) up to 90% relative humidity (non-condensing)
Weight:	5 pounds (2.3 kilograms)

**'PC' OPTION**

When ordered with a Research Inc. single lamp, infrared heater in the PC option, the Model 5620 is shipped from the factory supplied with all necessary interface wiring to connect to the heater. The Model 5620 is also shipped fully configured for the appropriate voltage for use with the particular heater. No other wiring beyond power input is required to make the Model 5620 & infrared heater 'system' fully operational.

Figure 7-1 Model 5620 Power Controller

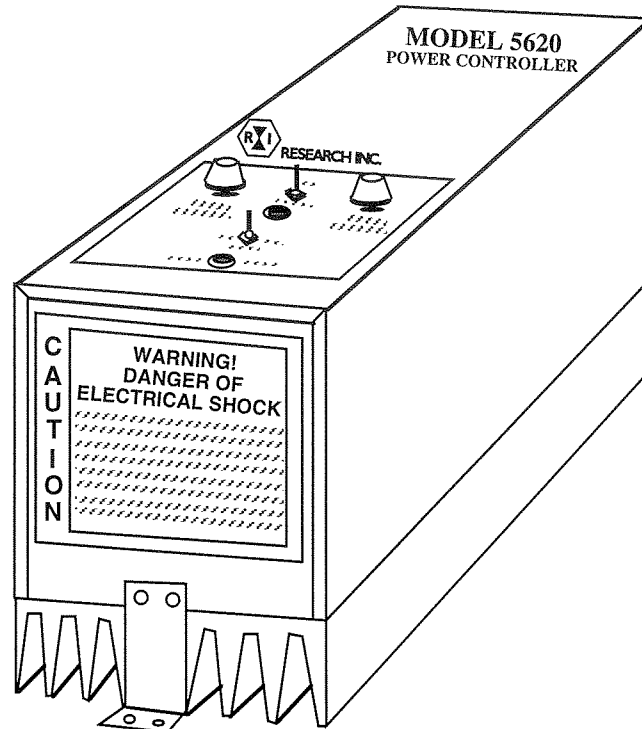
**SAFETY****General**

The Model 5620 Power Controller is designed for safe operation. Nevertheless, installation, maintenance and operation of the Model 5620 can be dangerous for a careless operator or maintenance person. For your safety and the safety of others, please read the instructions in this Instruction Manual, heed all CAUTION! and WARNING! labels and follow these safety practices which help prevent accident or injury.

**Electrical Safety**

There is a danger of electrical shock when servicing this control unit or its connected load. Please read the CAUTION WARNING label located on the 5620. Please adhere to these warnings.

**⚠ WARNING!**

Always disconnect the external power lines whenever servicing the controller, or the load.

**⚠ WARNING!**  
 Never operate the controller with the cover of the control box removed. This cover is designed to protect the operator from high voltages.

## INSTALLATION

### Installing the Model 5620

Installing the Model 5620 Power Controller is a quick and simple process. It requires:

- Connecting the LOAD wires
  - Selecting the proper output conditioning
  - Connecting an external timer-start switch (optional)
  - Connecting the LINE wires (main power)
1. Using a Phillips screwdriver, remove the four Phillips screws on the front of the 5620 and lift the top cover off.
  2. With a straight edge screwdriver, loosen the screws on the two lower strain relief clamps, located on the upper end of the 5620, enough to allow passage of the required wiring. If using an external timer-start switch, loosen the screws on the upper strain relief clamp as well.

Figure 7-2 Location of strain relief clamps and wiring access

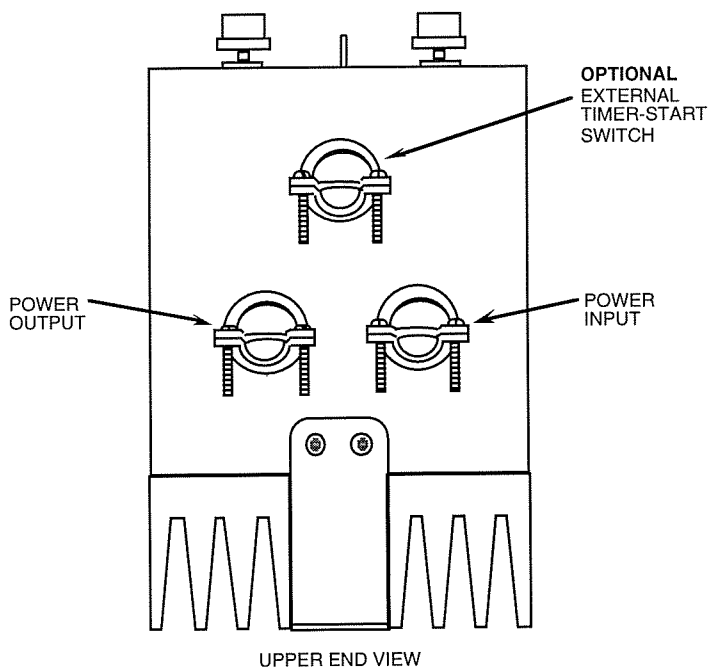

### Connecting the LOAD and LINE Wires

1. Pass the power source wire through the right lower strain relief clamp, and connect the wires to terminals labeled: LINE 1, LINE 2 and GROUND.
2. Pass the load wire through the left lower strain relief clamp, and connect the wires to terminals labeled: LOAD 1, LOAD 2 and GROUND.

**NOTE**

A cable with 1/4-turn safety plug is included with the Model 5620 SCR controllers ordered as PC option.

3. Tighten the screws on the strain relief clamps to secure the wires.

**CAUTION!**

Line 2 must be neutral for all 120V installations.

**WARNING!**

Never operate the controller without proper GROUND wiring.

Figure 7-3 Location of LINE, LOAD, and GROUND terminals

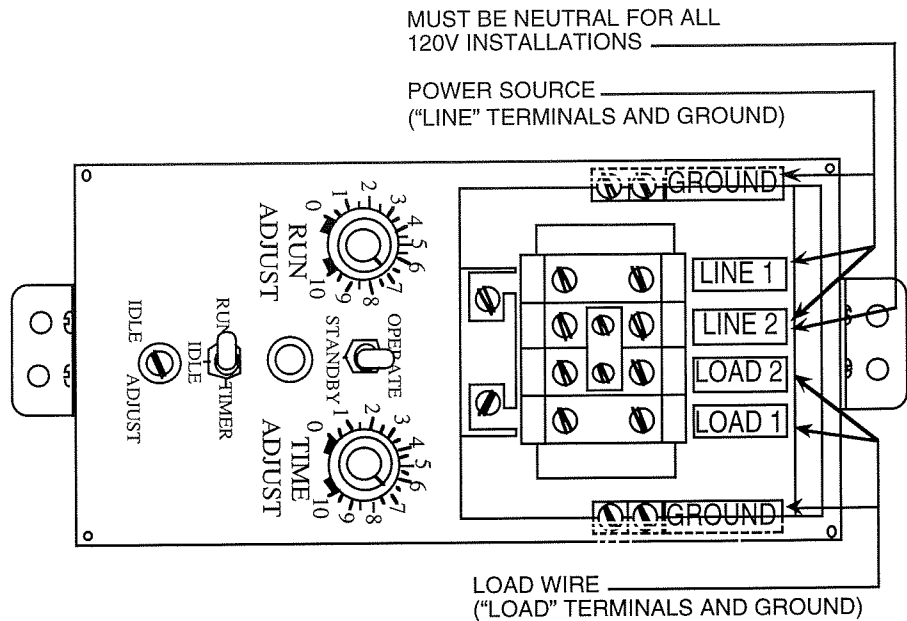

4942

### Output Conditioning Selection

The 5620 Power Controller has a jumper-selectable output conditioning feature, located on the lower circuit board, that changes the output voltage response time.

This feature protects the controller from excessive in-rush current when connected to resistive loads that have low resistance when cold. The three different response time settings are:

**Fast:**

For resistive loads where the cold-to-hot resistance is nearly constant. (.045 sec response time)

**Ramp:**

For rapidly responding resistive loads where the load resistance increases less than twice from cold to hot. (1 sec. response time)

**Lamp:**

For rapidly responding resistive loads, such as tungsten filament lamps, where the hot resistance is more than twice the cold resistance. (5 sec. response time)

Figure 7-4 Jumper positions for Fast, Ramp, or Lamp response time settings

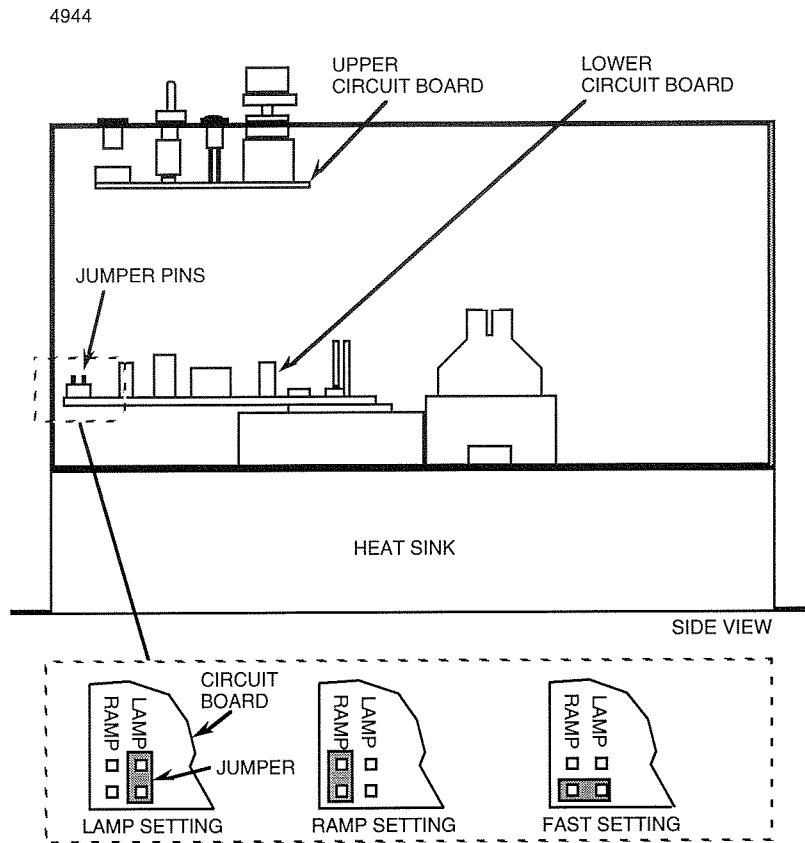

**Installing an Optional Remote Timer-Start Switch**

1. Remove the plug from the upper circuit board.
2. Pass the Remote Timer-Start switch wire through the top strain relief clamp.
3. Fasten the two wires from a normally-open switch into the small compression lugs on the plug and tighten the screws.
4. Re-insert the plug onto the board.
5. Tighten the screws on the strain relief clamp to secure the wire.
6. Replace the top cover and the four Phillips screws.

Figure 7-5 Installing the Remote Timer-Start switch to the upper circuit board

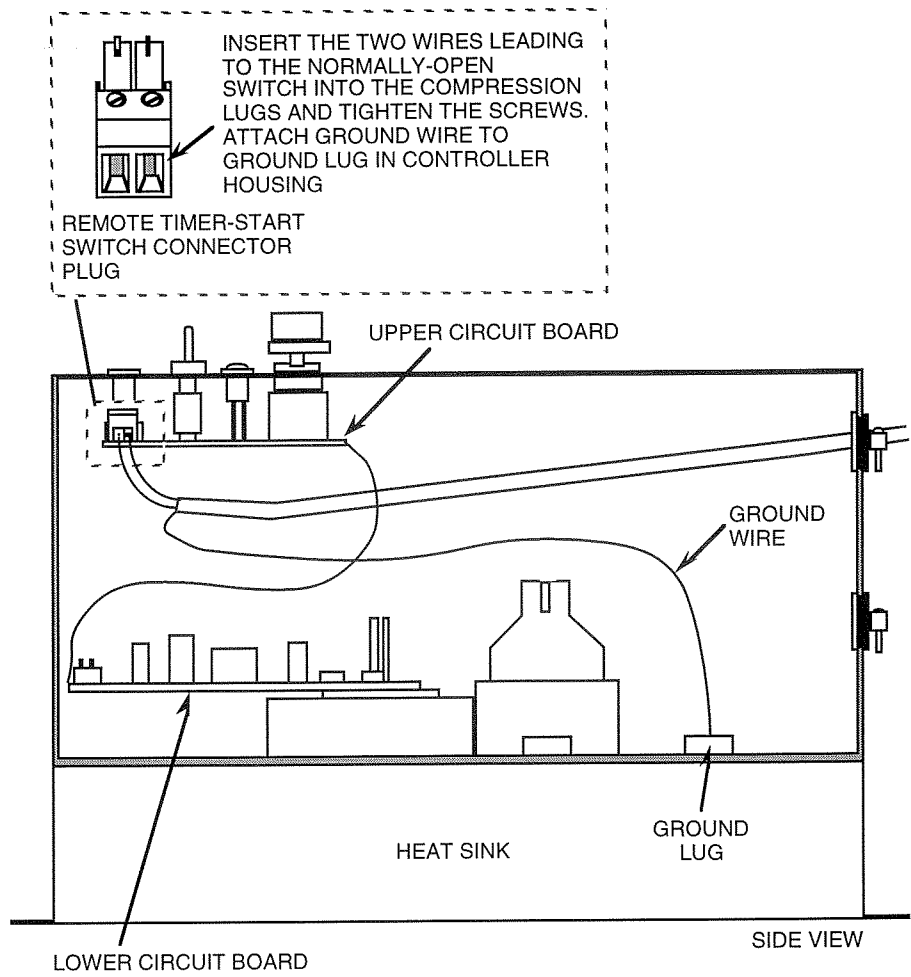

4945

# OPERATION

Fig. 7-6 displays the control panel for the 5620, and the following subsections describe how to use each feature.

Figure 7-6 Model 5620 Control Panel

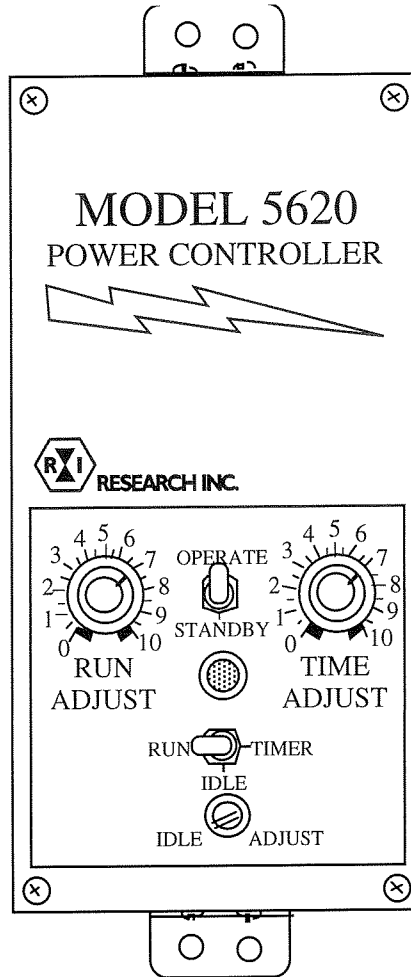

### How to Use the Standby-Operate Switch

The standby-operate switch disables the voltage output when in the standby position and enables the output when in the operate position.

**⚠ WARNING!**

This switch does NOT disconnect the load from the power line.

### Operating the RUN/IDLE/TIMER Features

The RUN/TIME ADJUST potentiometers provide a variety of operating modes. Using the RUN mode, the user can adjust the output from 0 to 100 percent of the input voltage. The TIME mode allows the user to preset a time of operation from 0 to 20 seconds.

#### IDLE Adjustment

1. Place the STANDBY-OPERATE switch in the OPERATE position.

2. Place the RUN/IDLE/TIMER switch in the IDLE position.
3. Using a 1/8 inch or less straight edge screwdriver, set the IDLE ADJUST to the desired idle output, from 0 to 15 percent. Lamps should be barely glowing.

#### **RUN Adjustment**

1. Place the RUN/IDLE/TIMER switch to the RUN position.
2. Set the run output by turning the RUN ADJUST potentiometer knob until the desired output voltage is reached.

#### **TIME Adjustment**

1. Set the amount of time for operation by turning the TIME ADJUST potentiometer knob. (0 to 10 on the dial corresponds to 0 to 20 seconds.)
2. To activate the time cycle, toggle the RUN/IDLE/TIMER switch to the TIMER position and release. The switch will return to the IDLE position.

When the timer is activated, the controller switches from the IDLE mode to the RUN mode, and returns to idle after the time cycle is complete.

**Model 4150  
Infrared Spot Heater  
Instruction Manual**

**098217-001 Rev. B**

**REVISION HISTORY**

<b>REV.</b>	<b>ECN</b>	<b>DESCRIPTION</b>	<b>DRAFT</b>	<b>CHKR</b>	<b>ENG.</b>	<b>DATE</b>
A	15535	Initial Release	JG/JL	JL	BR	3/6/98
B	16219	Added PC Option	JG	JL	BR	9/98

**Print Room Use Only**